

Simply the best from Germany

**KILIA**



**Shop Mincer H 82**

*Meister Plus*

**KILIA** Fleischerei- und Spezial-  
Maschinen-Fabrik GmbH

Christianstraße 160-164  
24536 Neumünster • Germany  
Tel +49 (0) 4321 3092 00  
Fax +49 (0) 4321 3092 88  
e-mail [kilia@kilia.com](mailto:kilia@kilia.com)  
<http://www.kilia.com>

DIN EN ISO 9001  
zertifiziert



Zertifikat Nr.

CERT-09475-2000-AQ-ESN-TGA



**Enterprise**



**Unger, 3-parts**

The **KILIA Meister Plus Shop Mincer H82** convinces by its remarkable value price performance ratio. Robust, reliable and easy to clean, it was designed specially for butcheries, supermarkets and meat processing businesses.

The machine is characterised by the following features:

- compact construction in stainless steel
- removable feed pan stainless steel
- stainless steel head
- ventilated motor and designed for continuous mincing
- one forward speed, one reverse
- start/stop push buttons with NVR system
- easy to clean
- meets the CE standards for hygiene and safety as well as the specific standards for meat mincers

The KILIA Meister Plus Shop Mincer H82 is available with two cutting set specifications:

- Enterprise: one plate and one self-sharpening knife stainless steel
- Unger: 3 parts cutting set

On request the machine is available in special voltage differing from 400 Volt, 50 Hz.

**Machine dimensions in mm:**

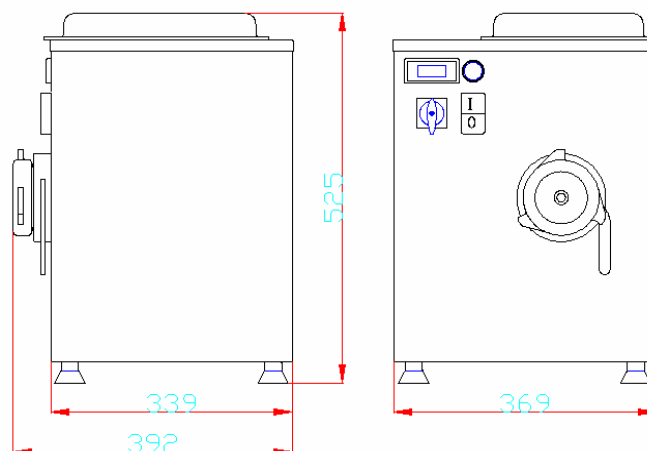

**Technical Data:** Capacity 350 kg / h; Motor power 1,1 kW; Weight net ca. 56 kg